

MAH series

時代の要求に応えた減速機。

高効率・高減速比ウォーム減速機
MAFシリーズ新登場。

特長

MAHシリーズ ウォーム減速機

マキエース

時代の要求に応えた減速機、「マキエース」の強力な特長をさらに活かし、MAシリーズの高効率をそのまま組合わせた高品質二段ウォーム減速機MAHシリーズとして新登場。

型番	50～160の7型番ラインアップ
減速比	高減速1/100～1/3600
特徴	ハイポイドやヘリカルギアに比べると滑り伝導のため、滑らかで静粛な運転が可能です

MAH シリーズ INDEX

呼び形式	A-97
主仕様	
標準品	A-97
市販部品リスト・排油栓・グリースニップル	A-98
定格伝達能力表	
MAH・MAHO	A-99
モータ付定格伝達能力表	A-101
外形寸法図	A-102

呼び形式

マキエース

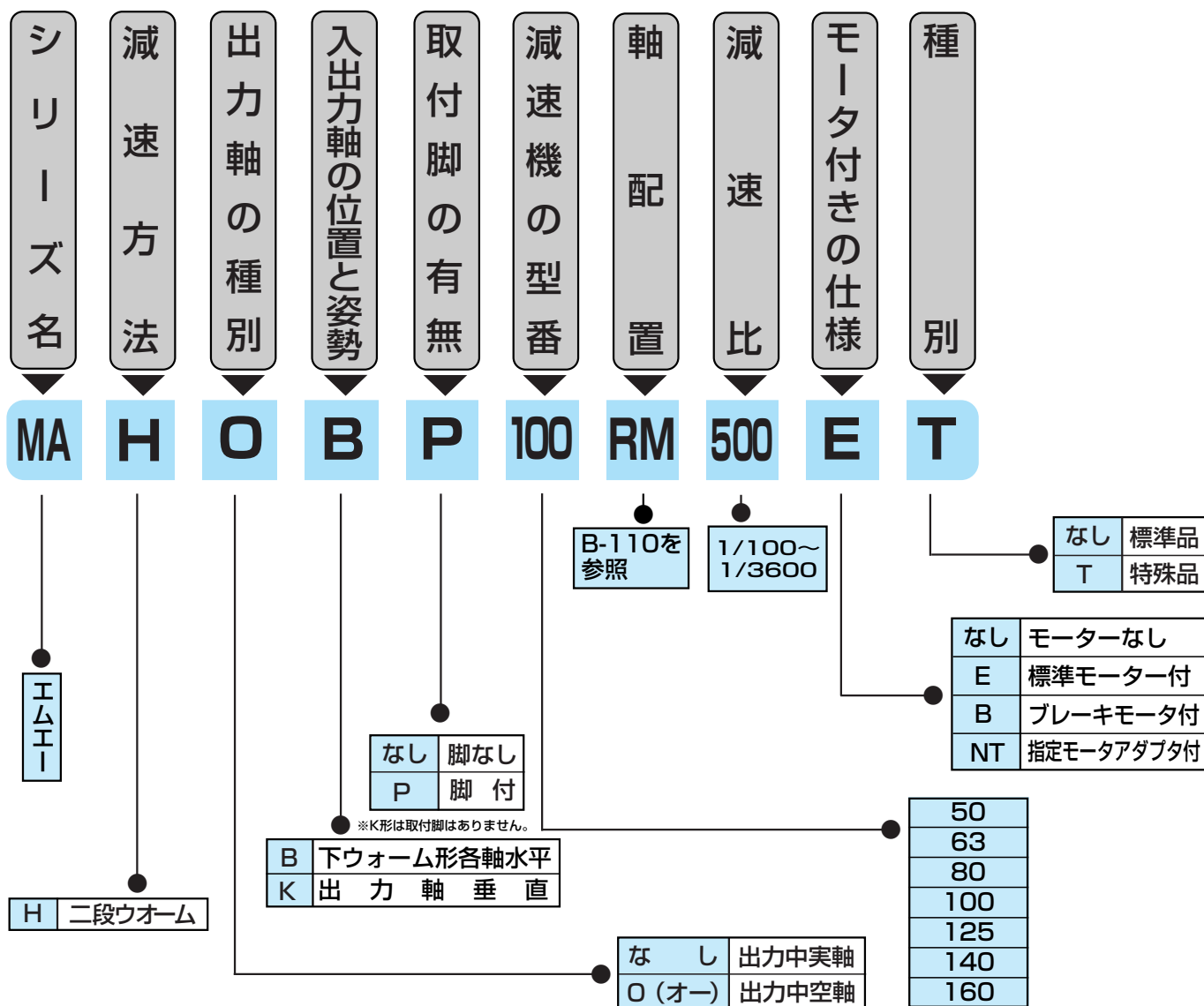

主仕様

標準品

No	項目	仕様
1	型番 (サイズ)	50 63 80 100 125 140 160
2	減速比	1/100~1/3600
3	出力軸形状	中実軸 (MAH形) 中空軸 (MAHO形)
4	入力軸/出力軸の位置と姿勢	下ウォーム形 (MAHB)
		出力軸垂直形 (MAHK)
5	入力軸形状	中実軸
		モータ付・ブレーキモータ付
6	塗装	マンセル5.5PB5.5/9スカイブルー (ラッカー系)
7	軸端キー	JIS B 1301-1996 (平行キー)
8	ウォームねじ	右ねじれ

市販部品リスト

型番	1次側				2次側									
	軸受		オイルシール		入力軸	軸受						オイルシール		
	入力軸	出力中空軸	入力軸	出力中空軸		出力中空軸				出力中空軸		入力軸	出力中空軸	出力中空軸
		B,K				B	K 上軸	K 下軸	B	K				
50	30203	6007	TC15307	TC335011	32005	6206UU	上 6206UU	上 6009UU	6009UU	上 6009UU	GMHS24408	HTC295011	D406211	
						6009UU	下 6009	下 6206		下 6009				
63	30203	6007	TC15307	TC335011	30205	6207UU	上 6206UU	上 6010UU	6010UU	上 6010UU	GMHS24408	HTC345511	D456812	
						6010UU	下 6010	下 6206		下 6010				
80	32005	6009	HTC24408	D406211	32206	32209	32209	32013	32013	HRE295011	HTC446812	D608212		
100	30205	6010	HTC24408	D456812	32207	32210	32210	32210	32015	32015	HTC345511	HTC497212	D709513	
						32015								
125	32206	32013	HRE295011	D608212	32210	32214	32214	32214	32019	32019	HTC446812	HTC658812	D9011513	
						32019								
140	32206	32013	HRE295011	D608212	30310	32215	32215	32215	32021	32021	HTC446812	HTC709513	D10012513	
						32021								
160	32207	32015	HTC345511	D709513	30311	32216	32216	32216	32024	32024	D507212	D7510013	D11514514	
						32024								

注・排油栓、グリースニップルそして油面計

型番	1次側				2次側			
	注油栓	排油栓	グリース	油面計	注油栓	排油栓	グリース	油面計
			ニップル				ニップル	
50	—	—	—	—	G3/8	R3/8	—	207
63	—	—	—	—	G3/8	R3/8	—	257
80	G3/8	R1/8	—	207	G1/2	R1/2	R1/8	KCM30
100	G3/8	R1/8	—	257	G1/2	R1/2	R1/8	308
125	G1/2	R1/2	—	308	G1/2	R1/2	R1/8	308
140	G1/2	R1/2	—	308	G1/2	R1/2	R1/8	4010
160	G1/2	R1/2	—	308	G1/2	R1/2	R1/8	4010

定格伝達能力表 (10時間連続定格)

マキエース

減速比	入力回転数 (rpm)	MAH50			MAH63			MAH80		
		入力(kW)	出力トルク (Nm)	総合効率 (%)	入力(kW)	出力トルク (Nm)	総合効率 (%)	入力(kW)	出力トルク (Nm)	総合効率 (%)
200	1800	0.30	190	59.9	0.55	355	60.5	0.92	681	70.0
	1500	0.26	199	59.0	0.49	370	59.3	0.81	705	68.3
	1200	0.22	206	57.6	0.42	389	57.9	0.70	742	66.7
	1000	0.20	213	57.2	0.37	401	57.3	0.61	769	65.7
	900	0.18	216	56.3	0.34	408	56.3	0.57	783	65.0
	750	0.16	222	55.1	0.30	420	55.0	0.49	804	63.8
	500	0.12	240	53.1	0.22	450	53.4	0.36	859	62.0
	250	0.07	279	50.2	0.13	516	50.3	0.22	980	58.2
300	1800	0.03	294	47.3	0.06	530	47.1	0.10	980	54.0
	1500	0.28	242	54.2	0.52	450	54.3	0.71	742	65.6
	1200	0.24	250	53.6	0.45	464	53.5	0.63	769	64.3
	1000	0.21	258	52.5	0.38	480	52.3	0.53	793	62.9
	900	0.18	272	51.6	0.34	495	51.4	0.46	822	62.0
	750	0.17	272	49.8	0.32	505	49.8	0.43	837	61.4
	500	0.15	283	48.6	0.28	518	49.0	0.37	859	60.2
	250	0.11	300	46.4	0.20	530	46.5	0.28	921	58.4
400	1800	0.06	300	43.5	0.11	530	43.3	0.16	980	53.9
	1500	0.03	300	40.1	0.05	530	39.8	0.07	980	50.1
	1200	0.19	216	52.9	0.36	408	53.0	0.58	783	63.4
	1000	0.17	222	52.3	0.32	420	52.3	0.51	804	62.2
	900	0.14	232	51.3	0.27	436	51.2	0.43	837	61.2
	750	0.13	240	50.0	0.23	450	50.7	0.37	859	60.0
	500	0.12	245	48.3	0.22	456	48.8	0.35	875	59.4
	250	0.11	254	47.2	0.20	474	47.5	0.30	903	58.5
500	1800	0.08	279	45.1	0.15	516	45.2	0.23	980	55.7
	1500	0.05	295	42.4	0.08	530	42.2	0.12	980	51.8
	1200	0.02	300	38.8	0.04	530	38.9	0.05	980	48.7
	1000	0.14	188	50.8	0.27	373	51.3	0.50	811	61.3
	900	0.12	190	50.3	0.24	381	50.6	0.44	837	60.4
	750	0.10	192	49.2	0.20	385	49.6	0.37	866	59.3
	500	0.08	194	47.8	0.17	289	48.7	0.32	891	58.1
	250	0.08	195	46.2	0.16	392	47.0	0.30	910	57.5
600	1800	0.07	198	45.1	0.14	396	45.8	0.26	947	56.2
	1500	0.05	202	43.1	0.10	404	43.6	0.19	980	53.3
	1200	0.03	217	40.5	0.06	435	40.7	0.10	980	49.6
	1000	0.01	248	36.9	0.03	498	37.5	0.04	980	46.7
	900	0.15	232	48.6	0.28	436	48.5	0.46	837	57.6
	750	0.13	240	46.6	0.25	450	47.3	0.40	859	56.2
	500	0.12	250	45.2	0.21	465	45.5	0.34	891	55.1
	250	0.10	257	43.5	0.19	488	43.8	0.30	921	54.0
800	1800	0.10	266	42.9	0.18	500	43.1	0.28	947	52.9
	1500	0.09	279	41.9	0.16	516	41.9	0.25	980	51.2
	1200	0.06	291	39.8	0.12	530	39.7	0.18	980	48.5
	1000	0.04	298	35.8	0.07	530	35.6	0.10	980	44.6
	900	0.02	317	30.4	0.03	530	30.5	0.04	980	40.9
	750	0.17	254	35.1	0.24	456	44.6	0.37	875	55.1
	500	0.16	263	31.8	0.22	474	41.9	0.33	903	54.1
	250	0.14	275	31.4	0.20	500	39.9	0.28	947	52.6
1000	1800	0.12	280	30.8	0.17	516	39.2	0.25	980	50.7
	1500	0.11	282	30.7	0.16	530	39.1	0.23	980	49.8
	1200	0.10	286	29.5	0.14	530	37.6	0.20	980	48.4
	1000	0.07	289	26.9	0.10	530	34.2	0.14	980	45.8
	900	0.04	297	25.5	0.05	530	32.5	0.08	980	42.2
	750	0.02	300	21.6	0.02	530	28.2	0.03	980	38.6
	500	0.13	213	30.4	0.22	479	41.1	0.33	910	52.7
	250	0.12	217	29.5	0.19	500	40.7	0.29	947	51.1
1000	1800	0.10	223	27.7	0.17	522	37.9	0.25	980	49.4
	1500	0.09	232	27.6	0.15	530	37.9	0.22	980	47.6
	1200	0.08	236	27.1	0.13	530	37.2	0.20	980	46.9
	1000	0.07	242	26.2	0.12	530	36.0	0.17	980	45.6
	900	0.06	252	23.3	0.09	530	32.0	0.12	980	43.0
	750	0.03	262	22.0	0.04	530	30.9	0.07	980	39.4
	500	0.01	278	20.8	0.02	530	29.4	0.03	980	35.6

MAH100			MAH125			MAH140			MAH160		
入力(kW)	出力トルク(Nm)	総合効率(%)	入力(kW)	出力トルク(Nm)	総合効率(%)	入力(kW)	出力トルク(Nm)	総合効率(%)	入力(kW)	出力トルク(Nm)	総合効率(%)
1.52	1170	72.5	2.43	1910	74.1	3.10	2450	74.5	4.47	3570	75.3
1.29	1170	71.0	2.06	1910	72.9	2.63	2450	73.3	3.80	3570	73.8
1.07	1170	69.0	1.69	1910	71.2	2.16	2450	71.4	3.11	3570	72.2
0.91	1170	67.6	1.44	1910	69.6	1.83	2450	70.0	2.64	3570	70.7
0.82	1170	67.1	1.31	1910	68.8	1.67	2450	69.2	2.41	3570	69.9
0.70	1170	66.1	1.11	1910	67.5	1.42	2450	67.7	2.05	3570	68.3
0.48	1170	63.7	0.77	1910	65.2	0.98	2450	65.2	1.43	3570	65.6
0.25	1170	60.2	0.40	1910	61.9	0.52	2450	61.8	0.75	3570	62.0
0.11	1170	55.5	0.18	1910	56.6	0.23	2450	56.6	0.33	3570	56.8
1.07	1170	68.5	1.70	1910	70.7	2.17	2450	70.9	3.14	3570	71.3
0.92	1170	66.7	1.45	1910	69.1	1.84	2450	69.5	2.67	3570	70.1
0.75	1170	65.0	1.19	1910	67.0	1.53	2450	67.2	2.18	3570	68.6
0.64	1170	63.8	1.02	1910	65.6	1.30	2450	65.8	1.87	3570	66.6
0.58	1170	63.3	0.92	1910	64.9	1.18	2450	65.0	1.71	3570	65.6
0.49	1170	62.4	0.78	1910	63.9	1.00	2450	63.9	1.46	3570	64.2
0.34	1170	60.0	0.54	1910	61.6	0.68	2450	63.0	1.00	3570	62.0
0.18	1170	55.9	0.29	1910	57.4	0.37	2450	57.7	0.53	3570	58.4
0.08	1170	51.3	0.13	1910	52.7	0.16	2450	52.5	0.24	3570	52.5
0.84	1170	65.9	1.32	1910	68.0	1.69	2450	68.3	2.43	3570	69.3
0.71	1170	64.4	1.13	1910	66.2	1.45	2450	66.4	2.06	3570	68.0
0.58	1170	63.0	0.93	1910	64.4	1.19	2450	64.4	1.71	3570	65.7
0.49	1170	62.1	0.79	1910	63.1	1.02	2450	63.1	1.46	3570	64.1
0.45	1170	61.6	0.72	1910	62.5	0.92	2450	62.5	1.33	3570	63.3
0.38	1170	60.5	0.61	1910	61.6	0.78	2450	61.6	1.13	3570	62.2
0.26	1170	58.1	0.42	1910	59.3	0.48	2450	67.4	0.78	3570	60.1
0.14	1170	53.6	0.23	1910	54.5	0.29	2450	54.6	0.42	3570	55.7
0.06	1170	49.8	0.10	1910	50.2	0.13	2450	50.0	0.18	3570	50.7
0.69	1170	63.8	1.09	1910	65.9	1.40	2450	66.1	2.01	3570	67.1
0.59	1170	62.6	0.94	1910	64.1	1.20	2450	64.2	1.71	3570	65.6
0.48	1170	61.3	0.77	1910	62.5	0.98	2450	62.5	1.41	3570	63.4
0.41	1170	60.4	0.65	1910	61.4	0.84	2450	61.4	1.21	3570	62.0
0.37	1170	59.8	0.59	1910	60.8	0.76	2450	60.7	1.10	3570	61.3
0.31	1170	58.7	0.50	1910	60.1	0.64	2450	60.0	0.93	3570	60.3
0.22	1170	55.8	0.35	1910	57.1	0.45	2450	57.5	0.64	3570	58.0
0.12	1170	51.8	0.19	1910	52.5	0.24	2450	52.5	0.35	3570	53.3
0.05	1170	48.1	0.08	1910	48.5	0.11	2450	48.3	0.15	3570	48.6
0.61	1170	60.4	0.96	1910	62.7	1.23	2450	62.8	1.77	3570	63.5
0.52	1170	58.6	0.82	1910	61.2	1.05	2450	61.2	1.51	3570	62.0
0.43	1170	56.9	0.68	1910	59.0	0.87	2450	59.0	1.24	3570	60.3
0.37	1170	55.7	0.58	1910	57.7	0.74	2450	57.6	1.07	3570	58.4
0.33	1170	55.2	0.53	1910	57.0	0.68	2450	56.9	0.97	3570	57.5
0.28	1170	53.8	0.45	1910	56.0	0.57	2450	56.0	0.83	3570	56.2
0.20	1170	50.2	0.32	1910	52.5	0.41	2450	52.8	0.58	3570	54.0
0.11	1170	46.0	0.17	1910	47.9	0.22	2450	47.9	0.32	3570	48.4
0.05	1170	41.8	0.08	1910	43.4	0.10	2450	43.2	0.14	3570	43.3
0.48	1170	57.6	0.75	1910	59.9	0.96	2450	59.9	1.38	3570	60.9
0.41	1170	56.1	0.65	1910	57.9	0.83	2450	57.8	1.17	3570	59.8
0.34	1170	54.7	0.54	1910	55.9	0.69	2450	55.8	0.98	3570	57.4
0.29	1170	53.3	0.46	1910	54.7	0.59	2450	54.6	0.84	3570	55.9
0.26	1170	52.5	0.42	1910	53.9	0.54	2450	53.9	0.76	3570	55.1
0.23	1170	50.6	0.36	1910	52.3	0.46	2450	52.7	0.65	3570	54.0
0.16	1170	47.8	0.26	1910	48.9	0.33	2450	49.0	0.46	3570	50.7
0.09	1170	43.8	0.14	1910	44.5	0.18	2450	44.4	0.26	3570	45.8
0.04	1170	39.7	0.06	1910	40.2	0.08	2450	40.6	0.11	3570	41.2
0.40	1170	55.2	0.63	1910	57.5	0.80	2450	57.4	1.15	3570	58.5
0.34	1170	53.8	0.54	1910	55.5	0.69	2450	55.5	0.98	3570	57.2
0.28	1170	51.9	0.45	1910	53.7	0.57	2450	53.6	0.82	3570	54.9
0.24	1170	50.6	0.38	1910	52.1	0.49	2450	52.3	0.70	3570	53.3
0.22	1170	49.6	0.35	1910	51.2	0.45	2450	51.4	0.64	3570	52.5
0.19	1170	48.0	0.30	1910	49.8	0.38	2450	50.0	0.55	3570	51.0
0.13	1170	45.5	0.22	1910	46.4	0.28	2450	46.4	0.39	3570	47.6
0.07	1170	41.6	0.12	1910	42.3	0.15	2450	42.2	0.22	3570	42.9
0.03	1170	37.1	0.05	1910	37.6	0.07	2450	37.9	0.10	3570	38.5

モータ付定格伝達能力表

モータ容量・型番・減速比別出力トルク (MAH-E・MAKH-E・MAOH-E・MAOKH-E)

型番	kW 減速比	0.2		0.4		0.75		1.5		2.2		3.7	
		出力トルク(N・m)		出力トルク(N・m)		出力トルク(N・m)		出力トルク(N・m)		出力トルク(N・m)		出力トルク(N・m)	
		50Hz	60Hz	50Hz	60Hz	50Hz	60Hz	50Hz	60Hz	50Hz	60Hz	50Hz	60Hz
50	200	150	127										
	300	205	173										
	400	222	216										
	500	190	188										
	600	286	259										
	800	263	254										
	1000	217	213										
63	200	☆		302	257								
	300	☆		408	345								
	400	266	225										
	500	322	272										
	600	361	309										
	800	427	379										
	1000	500	436										
80	200					652	557						
	300			491	418								
	400			634	538								
	500			769	650								
	600			859	733								
	800			903	875								
	1000			947	910								
100	200					678	577	1170	1154				
	300					955	818	1170	1170				
	400			656	559	1170	1170						
	500			797	677	1170	1170						
	600			895	769	1170	1170						
	800			1143	978	1170	1170						
	1000			1170	1170	1170	1170						
125	200							1392	1179				
	300					990	844	1910	1688				
	400					1264	1082	1910	1910				
	500					1530	1311	1910	1910				
	600					1753	1497	1910	1910				
	800												
	1000												
140	200									2053	1739		
	300							1991	1693	2450	2450		
	400					1268	1087	2450	2174				
	500					1533	1315	2450	2450				
	600					1753	1499	2450	2450				
	800					2208	1907	2450	2450				
160	200											3477	2956
	300									2946	2497		
	400							2598	2206	3570	3236		
	500							3132	2670	3570	3570		
	600							3553	3032	3570	3570		
	800							3570	3570	3570	3570		

※ モータ容量が減速機能力をオーバーしていますので、本数値以下でご使用ください。

※ ☆の欄のモータも標準外ですが取付は可能です。

外形寸法図

MAHseries

マキエース

MAHBP

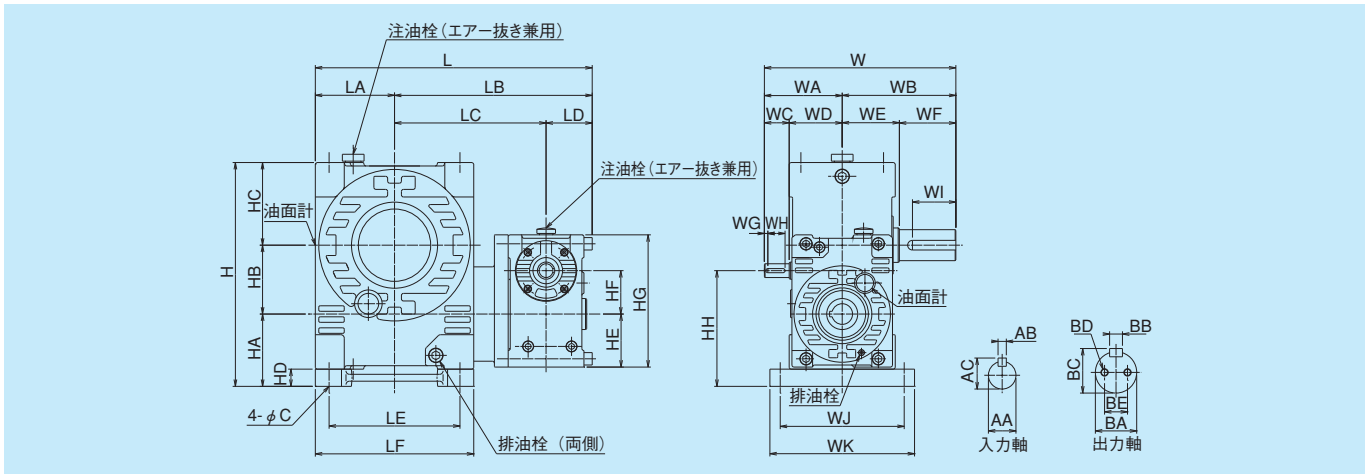

MAHBP

型番	L	LA	LB	LC	LD	LE	LF	W	WA	WB	WC	WD	WE	WF	WG	WH	WI	WJ	WK	H	HA	HB	HC	HD	HE	HF	HG	HH	AA	AB	AC	BA	BB	BC	BD	BE	C
50	228	65	163	120	43	100	130	184	87	97	25	62	55	42	-	18	32	130	150	185	70	50	65	20	55	40	135	110	φ12	4	13.5	φ25	8	28	1-M8x16	-	φ9
63	246	73	173	130	43	120	146	207	87	120	25	62	62	58	-	18	46	140	164	210	70	63	77	20	55	40	135	110	φ12	4	13.5	φ30	8	33	1-M8x16	-	φ11
80	335	100	235	175	60	150	190	230	100	130	28	72	72	58	5	21	45	160	190	265	89	80	96	25	65	50	167	139	φ18	6	20.5	φ38	10	41	2-M8x16	20	φ13
100	402	115	287	220	67	190	230	278	113	165	36	77	83	82	5	25	63	180	210	325	105	100	120	25	77	63	192	168	φ20	6	22.5	φ45	14	48.5	2-M8x16	25	φ13
125	487	145	342	265	77	240	290	350	145	205	42	103	100	105	6	30	81	230	265	407	132	125	150	32	99	80	246	212	φ25	8	28	φ60	18	64	2-M10x20	30	φ18
140	517	160	357	280	77	250	320	365	145	220	42	103	115	105	6	30	81	255	295	455	145	140	170	35	99	80	246	225	φ25	8	28	φ65	18	69	2-M12x24	35	φ18
160	590	185	405	325	80	300	370	400	165	235	42	123	130	105	6	30	80	295	340	510	160	160	190	40	123	100	306	260	φ28	8	31	φ70	20	74.5	2-M12x24	35	φ22

MAHKP

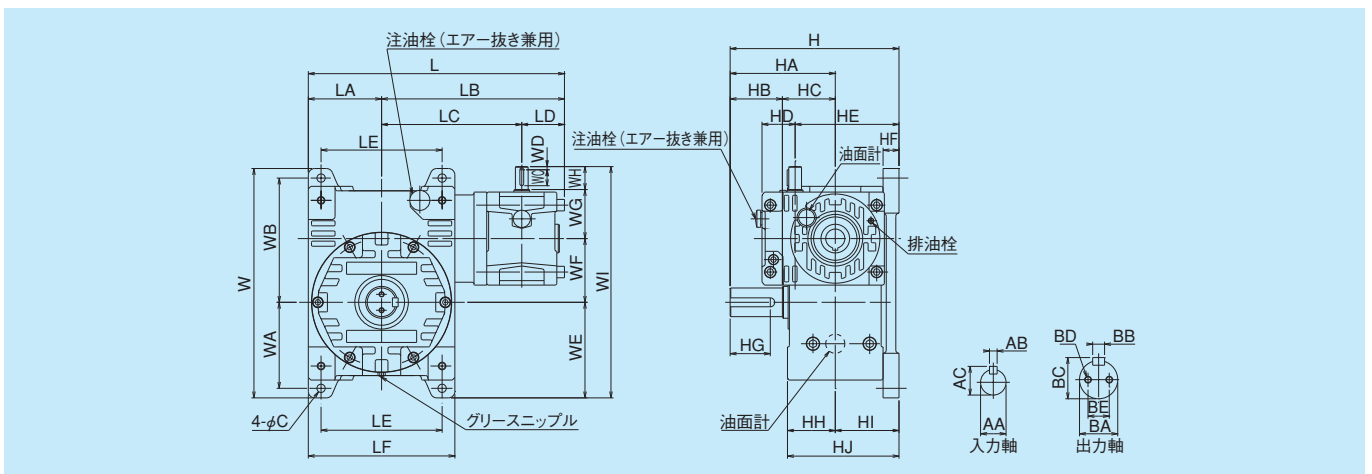

MAHKP

型番	L	LA	LB	LC	LD	LE	LF	W	WA	WB	WC	WD	WE	WF	WG	WH	WI	H	HA	HB	HC	HD	HE	HF	HG	HH	HI	HJ	AA	AB	AC	BA	BB	BC	BD	BE	C
50	228	65	163	120	43	100	130	215	80	115	18	-	90	50	62	25	227	162	97	42	55	40	105	15	32	50	65	115	φ12	4	13.5	φ25	8	28	1-M8x16	-	φ9
63	246	73	173	130	43	110	146	255	95	130	18	-	110	63	62	25	260	195	120	58	62	40	115	20	46	55	75	130	φ12	4	13.5	φ30	8	33	1-M8x16	-	φ11
80	330	95	235	175	60	150	190	305	115	160	21	5	130	80	72	28	310	220	130	58	72	52	140	25	45	65	90	155	φ18	6	20.5	φ38	10	41	2-M8x16	20	φ13
100	402	115	287	220	67	190	230	360	135	195	25	5	150	100	77	36	363	265	165	82	83	52	163	25	63	75	100	175	φ20	6	22.5	φ45	14	48.5	2-M8x16	25	φ13
125	487	145	342	265	77	240	290	450	170	245	30	6	187.5	125	103	42	457.5	332	205	105	100	67	207	32	81	95	127	222	φ25	8	28	φ60	18	64	2-M10x20	30	φ18
140	517	160	357	280	77	250	320	510	195	275	30	6	215	140	103	42	500	360	220	105	115	67	220	35	81	105	140	245	φ25	8	28	φ65	18	69	2-M12x24	35	φ18
160	590	185	405	325	80	300	370	580	220	310	30	6	245	160	123	42	570	395	235	105	130	82	260	40	80	120	160	280	φ28	8	31	φ70	20	74.5	2-M12x24	35	φ22

MAHBP

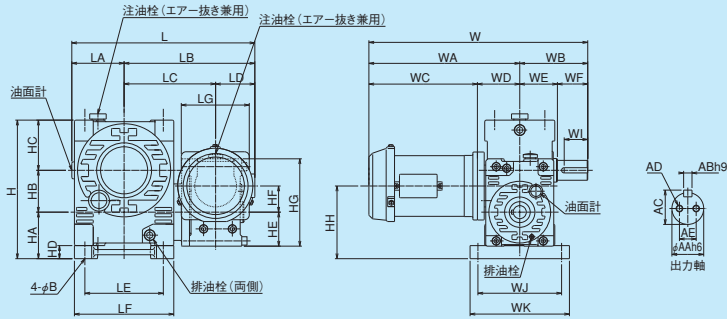

MAHBP

型番	モータ 容量	L	LA	LB	LC	LD	LE	LF	LG	W	WA	WB	WC	WD	WE	WF	WI	WJ	WK	H	HA	HB	HC	HD	HE	HF	HG	HH	HI	AA	AB	AC	AD	AE	B
50	0.2kW	301	65	236	120	116	100	130	114	341	294	97	169	75	55	42	32	130	150	185	70	50	65	20	55	40	153	110	φ116	25	8	28	1-M8深16	-	9
	0.2kW	319	73	246	130	116	120	146	114	364	294	120	169	75	62	58	46	140	164	210	70	63	77	20	55	40	153	110	φ116	30	8	33	1-M8深16	-	11
	0.4kW	319	73	246	130	116	120	146	114	384	264	120	189	75	62	58	46	140	164	210	70	63	77	20	55	40	153	110	φ116	30	8	33	1-M8深16	-	11
80	0.4kW	350	100	250	175	75	150	190	130	418.5	288.5	130	207.5	81	72	58	45	160	190	265	89	80	96	25	65	50	167	139	φ144	38	10	41	2-M8深16	20	13
	0.75kW	404	100	304	175	129	150	190	145	439.5	309.5	130	228.5	81	72	58	45	160	190	265	89	80	96	25	65	50	167	139	φ163	38	10	41	2-M8深16	20	13
100	0.4kW	410	115	295	220	75	190	230	130	464.5	299.5	165	207.5	92	83	82	63	180	210	325	105	100	120	25	77	63	192	168	φ144	45	14	48.5	2-M8深16	25	13
	0.75kW	464	115	349	220	129	190	230	145	485.5	320.5	165	228.5	92	83	82	63	180	210	325	105	100	120	25	77	63	192	168	φ163	45	14	48.5	2-M8深16	25	13
125	0.75kW	539	145	394	265	129	240	290	145	549.5	344.5	205	228.5	116	100	105	81	230	265	407	132	125	150	32	99	80	246	212	φ163	60	18	64	2-M10深20	30	18
	1.5kW	556	145	411	265	146	240	290	200	563	358	205	242	116	100	105	81	230	265	407	132	125	150	32	99	80	246	212	φ180	60	18	64	2-M10深20	30	18
140	0.75kW	569	160	409	280	129	250	320	145	568.5	348.5	220	228.5	120	115	105	81	255	295	455	145	140	170	35	99	80	246	225	φ163	65	18	69	2-M12深24	35	18
	1.5kW	586	160	426	280	146	250	320	200	582	362	220	242	120	115	105	81	255	295	455	145	140	170	35	99	80	246	225	φ180	65	18	69	2-M12深24	35	18
	1.5kW	656	185	471	325	146	300	370	225	655	420	235	242	141	130	105	88	295	340	510	160	160	190	40	123	100	306	260	φ180	70	20	74.5	2-M12深24	35	22
160	2.2kW	663	185	478	325	153	300	370	225	655	420	235	279	141	130	105	88	295	340	510	160	160	190	40	123	100	306	260	φ199	70	20	74.5	2-M12深24	35	22
	3.7kW	689	185	504	325	179	300	370	225	706	471	235	330	141	130	105	88	295	340	510	160	160	190	40	123	100	306	260	φ235	70	20	74.5	2-M12深24	35	22

MAHKP

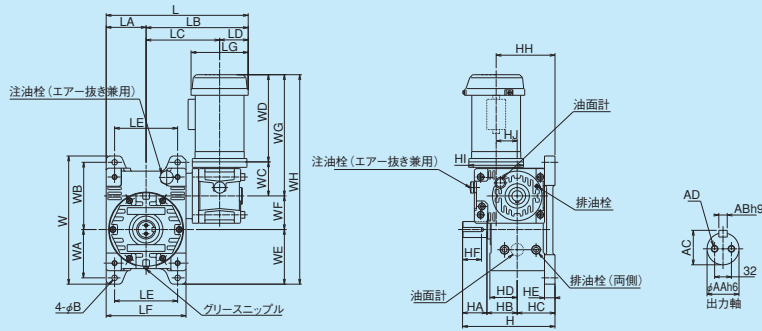

MAHKP

型番	モータ 容量	L	LA	LB	LC	LD	LE	LF	LG	W	WA	WB	WC	WD	WE	WF	WG	WH	H	HA	HB	HC	HD	HE	HF	HG	HH	HI	HJ	AA	AB	AC	AD	AE	B
50	0.2kW	243	65	178	120	58	100	130	116	215	90	115	75	169	90	50	244	384	162	42	55	65	50	15	32	58	105	114	40	25	8	28	1-M8深16	-	9
	0.2kW	261	65	188	130	58	110	146	116	255	95	130	75	169	110	63	244	417	195	58	62	75	55	20	46	58	115	114	40	30	8	33	1-M8深16	-	11
63	0.4kW	261	65	188	130	58	110	146	116	255	95	130	75	189	110	63	264	437	195	58	62	75	55	20	46	58	115	114	40	30	8	33	1-M8深16	-	11
	0.4kW	342	95	247	175	68	150	190	136	305	115	160	81	207.5	130	80	288.5	498.5	220	58	72	90	65	25	45	80	140	130	50	38	10	41	2-M8深16	20	13
80	0.75kW	351.5	95	255.5	175	81.5	150	190	161	305	115	160	81	228.5	130	80	309.5	519.5	220	58	72	90	65	25	45	88.5	140	145	50	38	10	41	2-M8深16	20	13
	0.4kW	403	115	288	220	68	190	230	136	360	135	195	89	207.5	150	100	299.5	549.5	265	82	83	100	75	25	63	80	163	130	63	45	14	48.5	2-M8深16	25	13
100	0.75kW	416.5	115	301.5	220	81.5	190	230	180	360	135	195	92	228.5	150	100	317.5	567.5	265	82	83	100	75	25	63	81.5	163	200	63	45	14	48.5	2-M8深16	25	13
	0.75kW	510	145	365	265	100	240	290	180	450	170	245	116	242	187.5	125	358	670.5	332	105	100	127	95	32	81	100	207	200	80	60	18	64	2-M10深20	30	18
125	1.5kW	510	145	365	265	100	240	290	180	450	170	245	116	242	187.5	125	358	670.5	332	105	100	127	95	32	81	100	207	200	80	60	18	64	2-M10深20	30	18
	0.75kW	540	160	380	280	100	250	320	180	510	195	275	116	242	215	140	358	713	360	105	115	140	105	35	81	100	220	200	80	65	18	69	2-M12深24	35	18
140	1.5kW	552.5	160	392.5	280	112.5	250	320	199	510	195	275	121	279	215	140	400	755	360	105	115	140	105	35	81	112.5	220	225	80	65	18	69	2-M12深24	35	18
	1.5kW	622.5	185	437.5	325	112.5	300	370	199	580	220	310	141	279	245	160	420	825	395	105	130	160	120	40	80	112.5	260	225	100	70	20	74.5	2-M12深24	35	22
	2.2kW	622.5	185	437.5	325	112.5	300	370	199	580	220	310	141	279	245	160	420	825	395	105	130	160	120	40	80	112.5	260	225	100	70	20	74.5	2-M12深24	35	22
160	3.7kW	627.5	185	442.5	325	117.5	300	370	235	580	220	310	141	330	245	160	471	876	395	105	130	160	120	40	80	159.5	306	225	100	70	20	74.5	2-M12深24	35	22